

LF-B Series

For Line, Medium Flow Flowmeter

Specifications

Flow Range	100L/min	Accuracy	± 5% (F.S)
Type of Flowmeter	OUT	Resisting Pressure	1MPa
Proof Pressure	0.5MPa	Accessories	Nil
Inlet Connection	3/4-16UNF	Approximate Weight	0.4kg
Outlet Connection	Hose Nipple 8.5mm		



Outline drawing

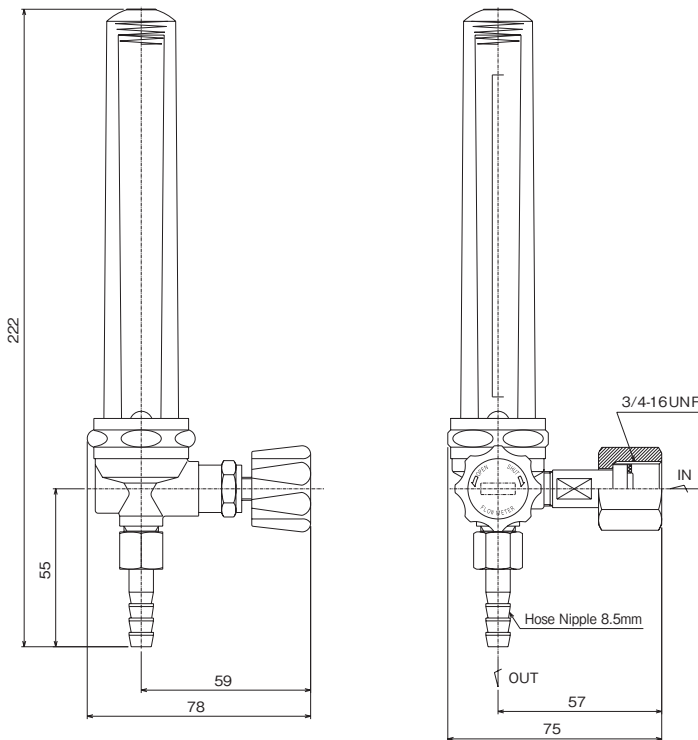

[Note]
 ■ Unit : mm
 ■ Dimensions are subject to change without notice.

Materials of construction

Body	C3771BE
Cover	PC
Hose Nipple	C3604BD
O Ring	NBR

List of specifications

Series	Applicable gas	Flow L/min	Type of Flowmeter	Proof Pressure MPa	Inlet Connection	Outlet Connection
LF-B	Ar	50	OUT	0.3	3/4-16UNF	Hose Nipple 8.5mm
	N ₂	50	OUT	0.3	3/4-16UNF	Hose Nipple 8.5mm
	CO ₂	50	OUT	0.3	3/4-16UNF	Hose Nipple 8.5mm
	Ar	100	OUT	0.5	3/4-16UNF	Hose Nipple 8.5mm
	N ₂	100	OUT	0.5	3/4-16UNF	Hose Nipple 8.5mm
	CO ₂	100	OUT	0.5	3/4-16UNF	Hose Nipple 8.5mm

General industrial use

Flowmeter

Gas Mixer

Medical use