

NF-P Series

For Panel Mount Flowmeter

Specifications

Flow Range	25L/min	Accuracy	± 5% (F.S)
Type of Flowmeter	IN	Resisting Pressure	1MPa
Proof Pressure	0.15MPa	Accessories	Nil
Inlet Connection	Hose Nipple 8.5mm	Approximate Weight	0.3kg
Outlet Connection	Hose Nipple 8.5mm		



Outline drawing

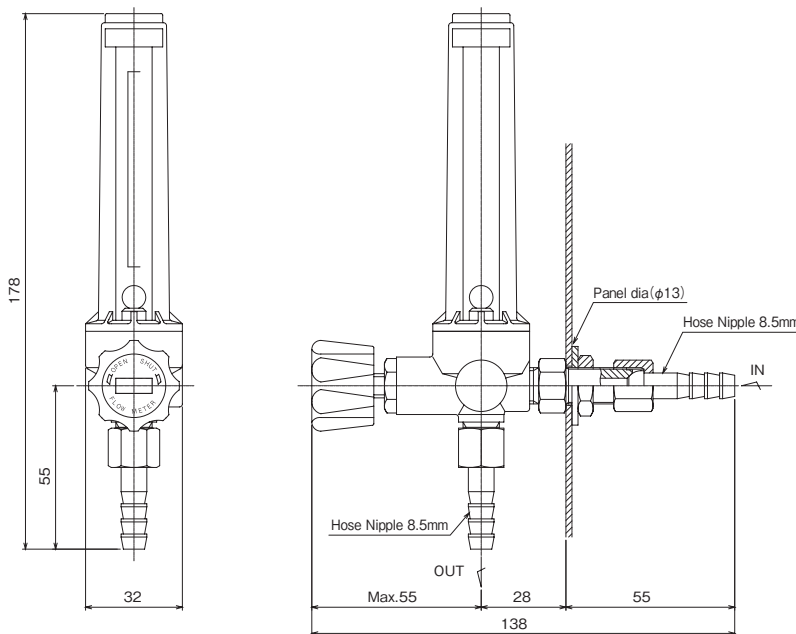

[Note]
 ■ Unit : mm
 ■ Dimention are subject to change without notice.

Materials of construction

Body	C3771BE
Cover	PC
Hose Nipple	C3604BD
O Ring	NBR

List of specifications

Series	Applicable gas	Flow L/min	Type of Flowmeter	Proof Pressure MPa	Inlet Connection	Outlet Connection
NF-P	Ar	25	IN	0.15	Hose Nipple 8.5mm	Hose Nipple 8.5mm
	N ₂	25	IN	0.15	Hose Nipple 8.5mm	Hose Nipple 8.5mm
	CO ₂	25	IN	0.15	Hose Nipple 8.5mm	Hose Nipple 8.5mm
	H ₂	30	IN	0.15	Hose Nipple 8.5mm	Hose Nipple 8.5mm
	He	30	IN	0.15	Hose Nipple 8.5mm	Hose Nipple 8.5mm
	Ar	25	IN	0.2	Hose Nipple 8.5mm	Hose Nipple 8.5mm

General industrial use

Flowmeter

Gas Mixer

Medical use