

NF Series

Standard Type Flowmeter

Specifications

Flow Range	25L/min	Accuracy	± 5% (F.S)
Type of Flowmeter	IN	Resisting Pressure	1MPa
Proof Pressure	0.15MPa	Accessories	Nil
Inlet Connection	G1/4 Male	Approximate Weight	0.3kg
Outlet Connection	Hose Nipple 8.5mm		



Outline drawing

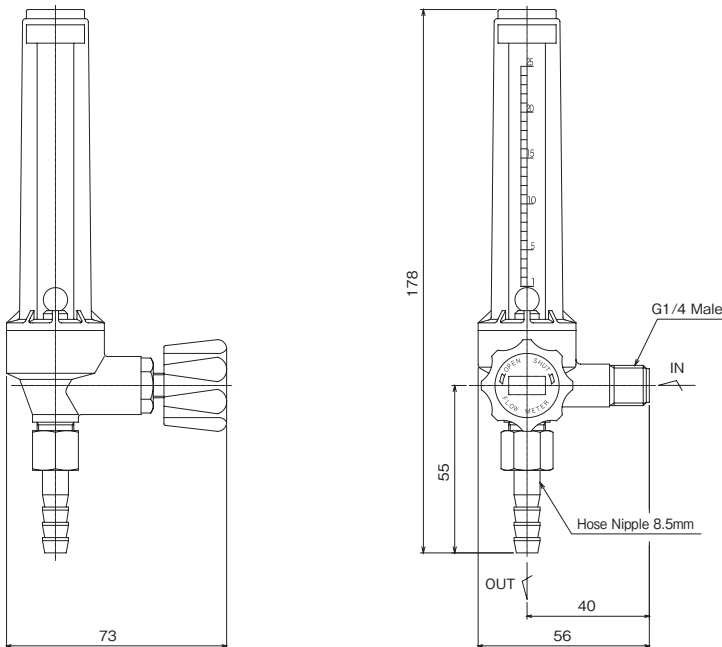

[Note]
 ■ Unit : mm
 ■ Dimensions are subject to change without notice.

Materials of construction

Body	C3771BE
Cover	PC
Hose Nipple	C3604BD
O Ring	NBR

List of specifications

Series	Applicable gas	Flow L/min	Type of Flowmeter	Proof Pressure MPa	Inlet Connection	Outlet Connection
NF	Ar	25	IN	0.15	G1/4 Male	Hose Nipple 8.5mm
	N ₂	25	IN	0.15	G1/4 Male	Hose Nipple 8.5mm
	CO ₂	25	IN	0.15	G1/4 Male	Hose Nipple 8.5mm
	H ₂	30	IN	0.15	G1/4 Male	Hose Nipple 8.5mm
	He	30	IN	0.15	G1/4 Male	Hose Nipple 8.5mm
	Ar	25	IN	0.2	G1/4 Male	Hose Nipple 8.5mm

General industrial use

Flowmeter

Gas Mixer

Medical use