

L96 Series

Absolute Pressure Regulator

Inlet Pressure	Max.1.0 MPaG (145 PSIG)
Outlet Pressure	-0.1 MPaG to 0.2 MPaG (-30 in HgG to 29.0 PSIG)
Proof Pressure	22.2 MPa (3,219 PSI)
CV	0.07
Temperature	-10°C to +40°C
Outboard Leakage	$1 \times 10^{-11} \text{ Pa} \cdot \text{m}^3/\text{sec} \cdot \text{He}$ ($1 \times 10^{-10} \text{ atm} \cdot \text{cc}/\text{sec} \cdot \text{He}$)
Internal Volume	5.739 cc (0.35 in ³) w/o fittings
Approximate weight	1.6 kg (3 lbs. 8 oz.)
Installation	Threaded holes on the rear surface

[NOTE]

1MPa = 10.2 kgf/cm² = 145.04 PSI

1MPa = 7504.36 mmHg = 295.4 inHg



Cross sectional drawing

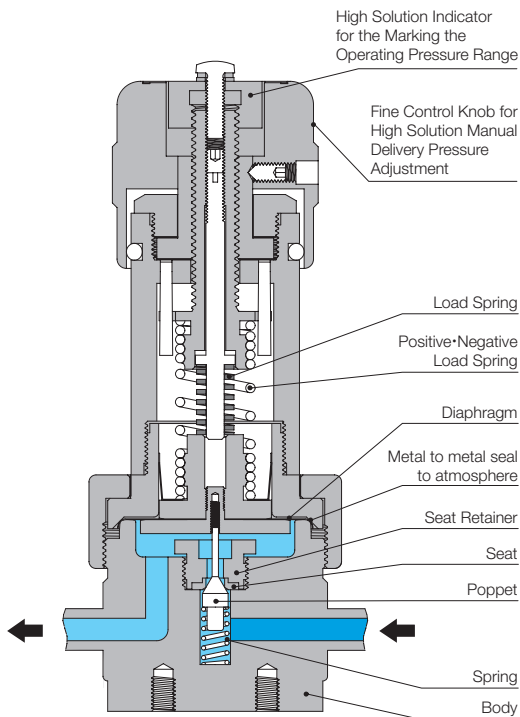

[NOTE]

- Avoid turning the control knob excessively.
- No filter in this unit.

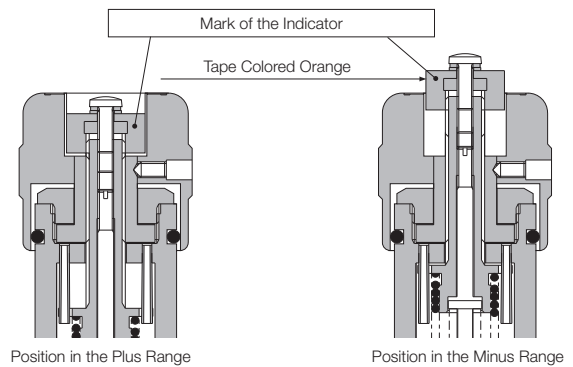

Flow characteristics

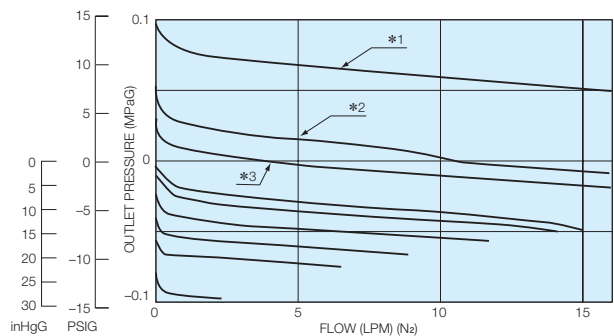

[NOTE]

- *1 Inlet Pressure=0.2MPaG (29.0 PSIG)
- *2 Inlet Pressure=0.1MPaG (14.5 PSIG)
- *3 Inlet Pressure=0.1MPaG (14.5 PSIG)
- Flow curves below 0 MPaG (0 PSIG) in the outlet pressure are under vacuumizing the outlet side.
- These tests were performed at ambient conditions.

Outline drawing

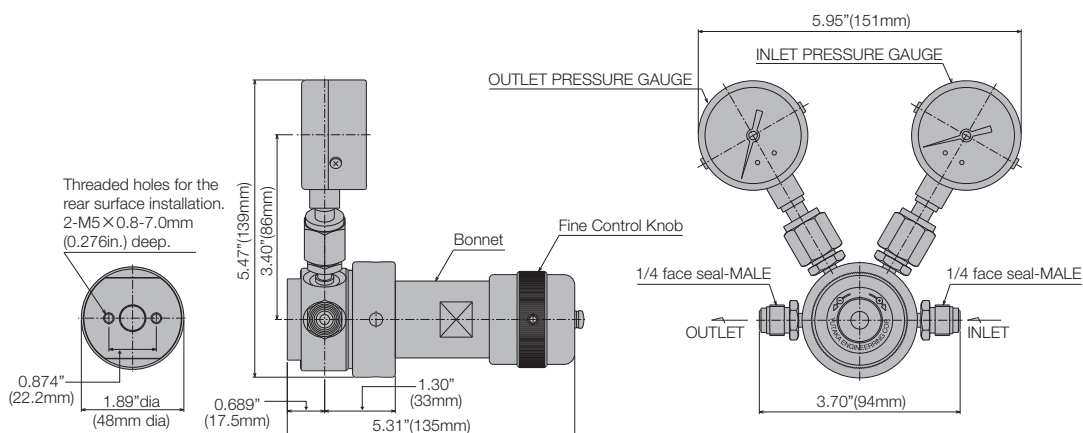

[NOTE]
 · Dimensions are in inches and (mm) for reference only.
 · Subject to change without notice.

Materials of construction

MODEL & TYPE	L96SS	L96SH	L96SS-CO
Wetted Parts			
Body	SUS316L		
Poppet & Seat Retainer	SUS316L	Hastelloy® C-22	SUS316L
Diaphragm	Hastelloy® C-22		SUS316L
Seat	PTFE		
Spring	SUS316L		
Gasket to seal for gauge	Ni		SUS316L
Non-wetted Parts			
Bonnet (B)	Chromium Plated Brass		
Cap	SUS304		
Stem	Nickel Plated Brass		
Control Knob	Chromium Plated Brass		

Wetted surface finishes

Standard Ra (GRADE "B")	32µin. (0.80µm) or less
Optional Ra (GRADE "A")	7µin. (0.18µm) or less

Standard connections

1/4" face to face length of the male and female are the same. **3.70in. (94mm)**
 1/4" Tube stubs and other connections available as options.

[NOTE]
 · Any combination of Face Seal male and/or female fittings are available for inlet and outlet.
 · Size and configuration of pressure gauge port is 1/4" Face Seal male.

Ordering information

