

MX-N Series

Standard Type Gas Mixer

Specifications

Model	MX-2SN	MX-2LN	MX-3S	MX-3L
Inlet Pressure	0.3~0.99MPa	0.4~0.99MPa		
Mixing Pressure	1~25L/min : 0.2MPa 10~100L/min : 0.5MPa		5~50L/min : 0.3MPa 20~200L/min : 0.5MPa	
Flow Range	1~25L/min	5~50L/min 10~100L/min 20~200L/min	1~25L/min	5~50L/min 10~100L/min 20~200L/min
Accuracy of Flowrate	±5%(F.S.)			
Accuracy of Mixing Ratio	±2.5%			
Inlet Connection	Hose Nipple 8.5mm			
Outlet Connection	20PH Coupler	30PH Coupler	20PH Coupler	30PH Coupler
Accessories	Nil			
Approximate Weight	9.8kg	12.9kg	15kg	



MX-2SN

Outline drawing

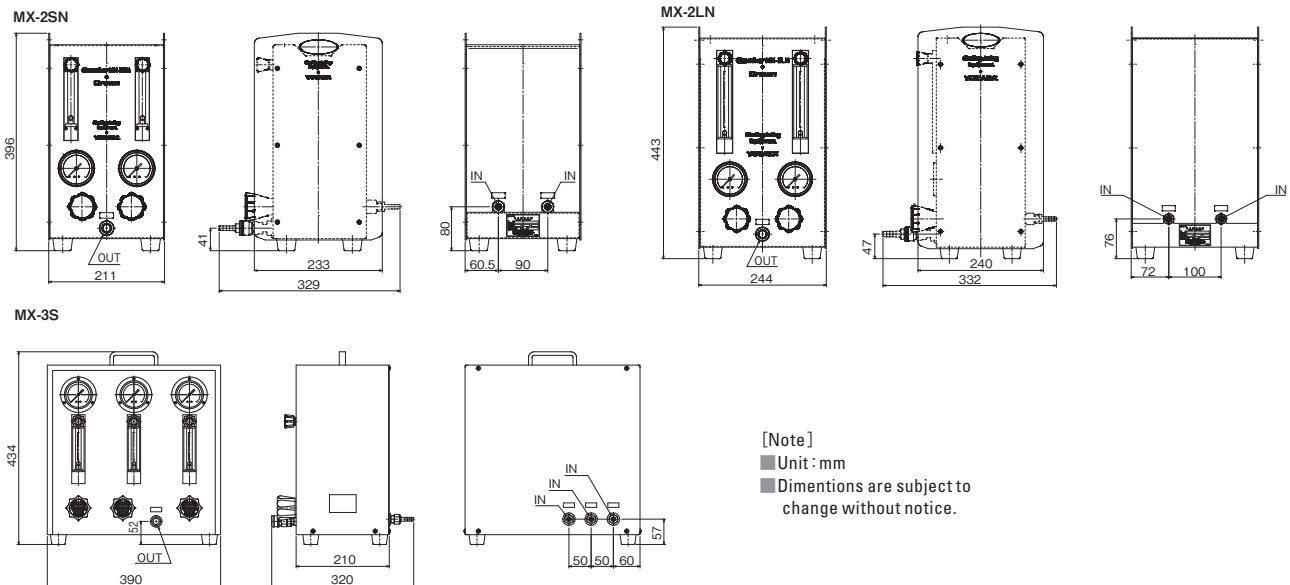

Flow Chart

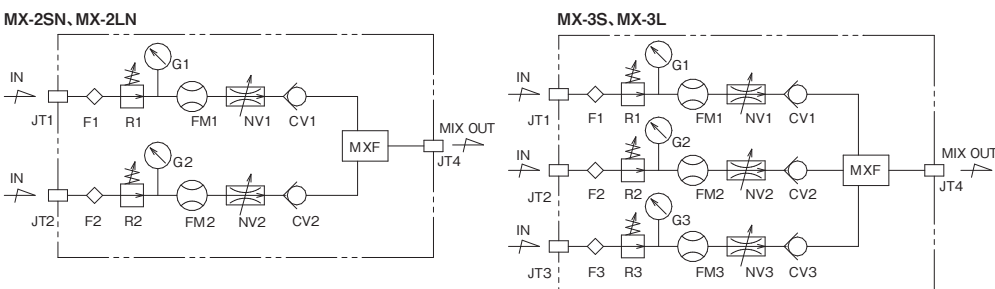

No	Sign	Name
1	JT1, 2, 3	Inlet Connection
2	F1, 2, 3	Filter
3	G1, 2, 3	Pressure Gauge
4	R1, 2, 3	Pressure Regulator
5	FM1, 2, 3	Flowmeter
6	NV1, 2, 3	Control Valve
7	CV1, 2, 3	Check Valve
8	MXF	Mixer
9	JT4	Outlet Connection