

# SMX-1 Series

## Compact Size Gas Mixer

### Specifications

Model	SMX-2S1	SMX-2L1
Inlet Pressure	0.3~0.99MPa	0.4~0.99MPa
Mixing Pressure	0.2MPa	0.3MPa
Flow Range	1~25L/min	5~50L/min
Accuracy of Flowrate	±5% (F.S.)	
Accuracy of Mixing Ratio	2.5%	
Inlet Connection	Hose Nipple 8.5mm	
Outlet Connection	20PH Coupler	
Accessories	Nil	
Approximate Weight	5.2kg	



### Outline drawing

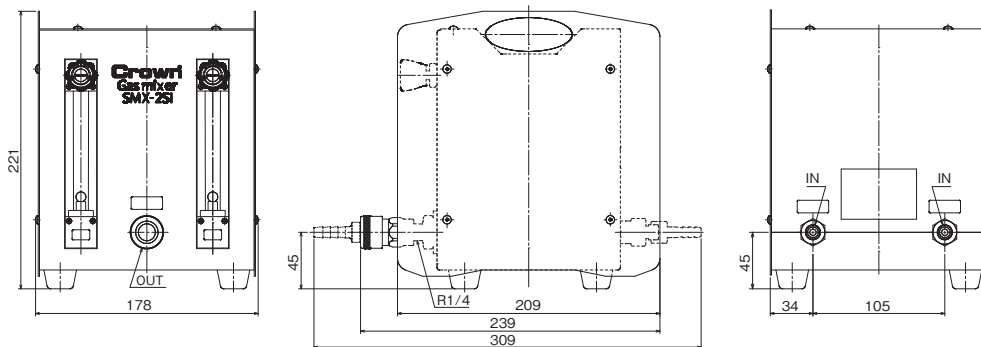

[Note]  
 ■ Unit : mm  
 ■ Dimention are subject to change without notice.

### Flow Chart

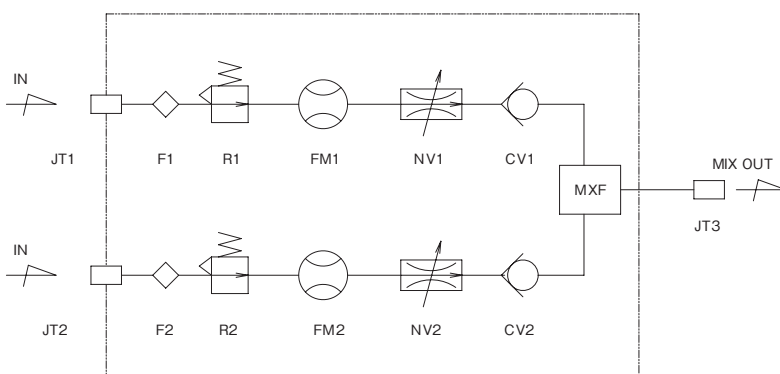

No	Sign	Name
1	JT1,2	Inlet Connection
2	F1,2	Filter
3	R1,2	Pressure Regulator
4	FM1,2	Flowmeter
5	NV1,2	Control Valve
6	CV1,2	Check Valve
7	MXF	Mixer
8	JT3	Outlet Connection

General Industrial use

Flowmeter

Gas Mixer

Medical use