

FCR-N Series

For Cylinder, Carbon Dioxide Pressure Regulator

Specifications

	FCR-50N	FCR-100N	FCR-150N	FCR-200N	FCR-500N
Inlet Pressure Gauge	25MPa				
Outlet Pressure Gauge	1MPa				
Inlet Pressure	12MPa or less				
Outlet Pressure	0.3MPa	0.5MPa	0.5MPa	0.6MPa	0.6MPa
Flow Range	5~50L/min	10~100L/min	10~150L/min	70~200L/min	50~500L/min
Type of Flowmeter	OUT	OUT	OUT	OUT	OUT
Proof Pressure	0.3MPa	0.5MPa	0.5MPa	0.6MPa	0.6MPa
Inlet Connection	W22-14 O.R.				
Outlet Connection	Hose Nipple 8.5mm				
Heater capacity	400W	600W	800W	1200W	2000W
Voltage	100V				200V
Power Supply cord	2m				3m
Accessories	Gasket Packing(Fiber)×2Pcs.				
Approximate Weight	3.3kg	3.6kg	4.5kg	4.5kg	8kg



Outline drawing

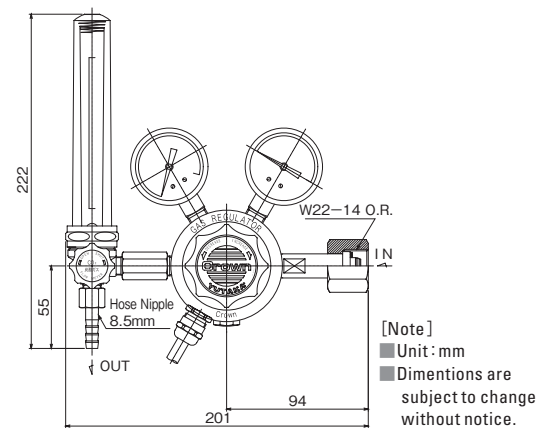
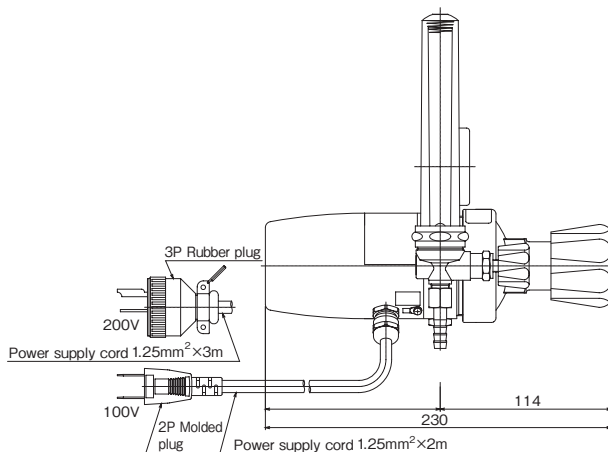

Supply pressure effect characteristics

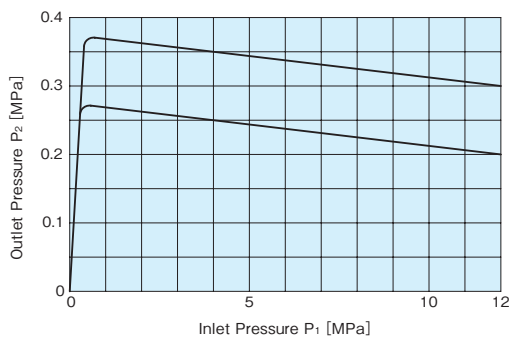

Materials of construction

Body	C3771BE
Bonnet	ADC12
Poppet	C3604BD
Seat	PCTFE
Diaphragm	NBR
Safety valve seat	NBR