

FR-I0-P Series

For Line Pressure Regulator

Specifications

Outlet Pressure Gauge	0.3, 0.6, 1MPa	Outlet Connection	Rc1/4
Inlet Pressure	0.99MPa or less	Accessories	Nil
Outlet Pressure	0 ~ 0.6MPa	Approximate Weight	1.2kg
Inlet Connection	Rc1/4		



Outline drawing

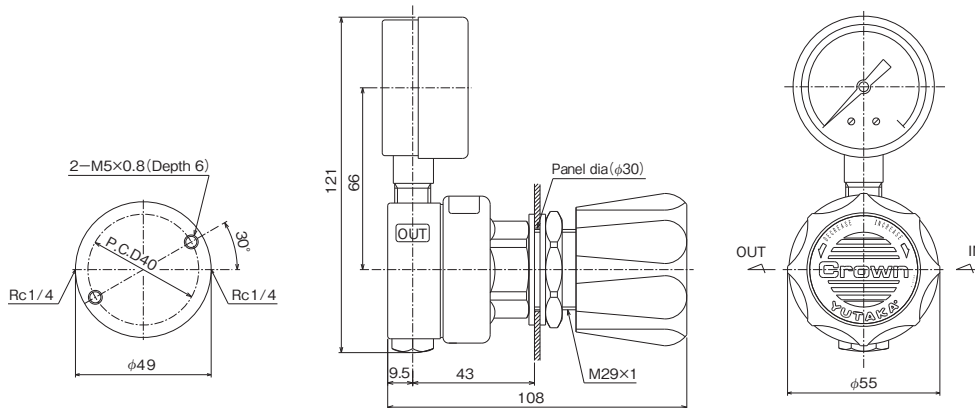

Flow characteristics

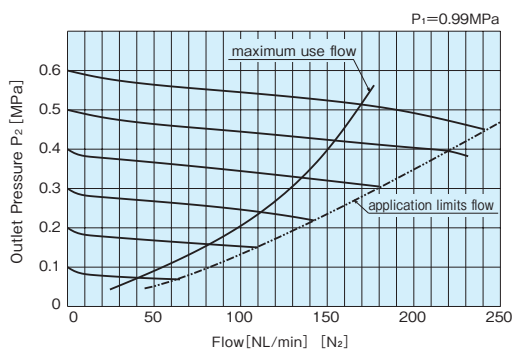

[Note]
■ These tests were performed at ambient conditions.

Materials of construction

Body	C3604 BD
Bonnet	ZDC
Poppet	C3604 BD
Seat	NBR
Diaphragm	NBR
Safety valve seat	NBR

List of specifications

Series	Inlet Pressure Gauge MPa	Inlet Connection	Outlet Connection
FR-I0-P	0.3	Rc1/4	Rc1/4
	0.6	Rc1/4	Rc1/4
	1	Rc1/4	Rc1/4
	0.3	1/4 SUS Pipe Nipple	1/4 SUS Pipe Nipple
	0.6	1/4 SUS Pipe Nipple	1/4 SUS Pipe Nipple
	1	1/4 SUS Pipe Nipple	1/4 SUS Pipe Nipple