

# FR-IS-P Series

## For Cylinder Single-Stage Pressure Regulator

### Specifications

Inlet Pressure Gauge	25MPa	Proof Pressure	0.15 or 0.2MPa
Outlet Pressure Gauge	0.6 MPa	Inlet Connection	W22-14 O.R.
Inlet Pressure	14.8MPa or less	Outlet Connection	Hose Nipple 8.5mm
Outlet Pressure	0 ~ 0.4 MPa	Accessories	Gasket Packing(Fiber)×2Pcs.
Flow Range	1~25L/min	Approximate Weight	1.6kg
Type of Flowmeter	IN		



### Outline drawing

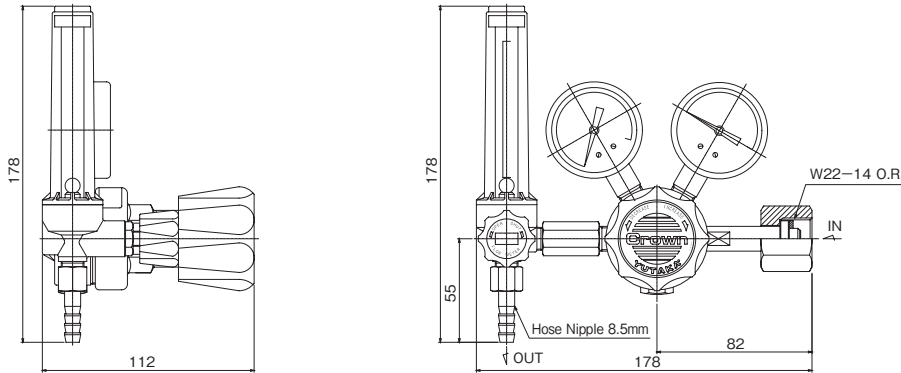

[Note]  
■ Unit : mm  
■ Dimensions are subject to change without notice.

### Supply pressure effect characteristics

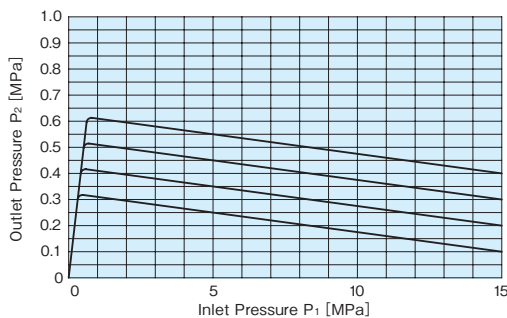

[Note]  
■ These tests were performed at ambient conditions.

### Materials of construction

Body	C3604 BD
Bonnet	ZDC
Poppet	C3604 BD
Seat	NBR
Diaphragm	NBR
Safety valve seat	NBR

### List of specifications

Series	Inlet Pressure Gauge MPa	Outlet Pressure Gauge MPa	Flowmeter				Inlet Connection	Outlet Connection
			Applicable gas	Flow L/min	Type of Flowmeter	Proof Pressure MPa		
FR-IS-P	25	0.6	Ar	25	IN	0.15	W22 (R)	Hose Nipple 8.5mm
	25	0.6	N <sub>2</sub>	25	IN	0.15	W22 (R)	Hose Nipple 8.5mm
	25	0.6	O <sub>2</sub>	25	IN	0.15	W22 (R)	Hose Nipple 8.5mm
	25	0.6	H <sub>2</sub>	30	IN	0.15	W22 (L)	Hose Nipple 8.5mm
	25	0.6	He	30	IN	0.15	W21 (L)	Hose Nipple 8.5mm
	25	0.6	Ar	25	IN	0.2	W22 (R)	Hose Nipple 8.5mm