

FR-II Series

For Cylinder Two-Stage Pressure Regulator

Specifications

Inlet Pressure Gauge	25MPa	Proof Pressure	0.25MPa
Inlet Pressure	14.8MPa or less	Inlet Connection	W22-14 O.R.
Outlet Pressure	0.25MPa	Outlet Connection	Hose Nipple 8.5mm
Flow Range	1~25L/min	Accessories	Gasket Packing(Fiber)×2Pcs.
Type of Flowmeter	OUT	Approximate Weight	2.0kg



Outline drawing

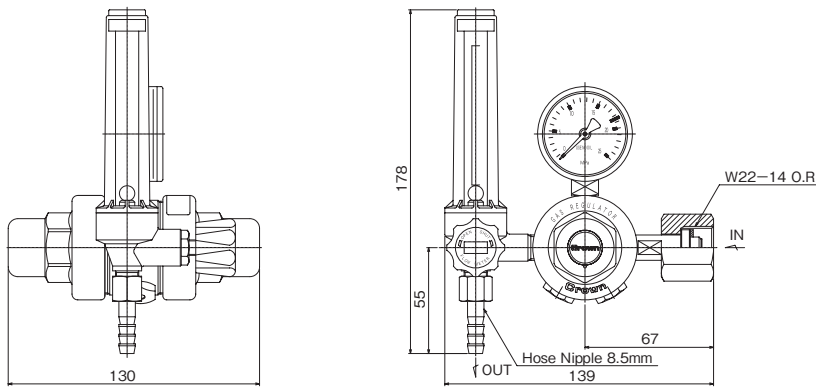

[Note]
■ Unit: mm
■ Dimensions are subject to change without notice.

Supply pressure effect characteristics

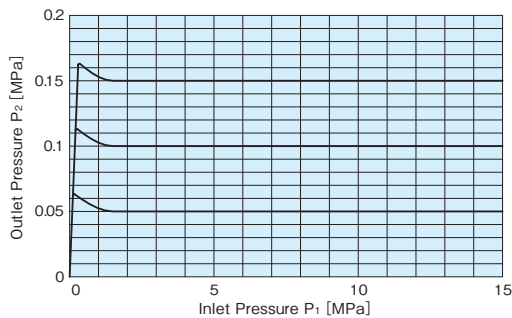

[Note]
■ These tests were performed at ambient conditions.

Materials of construction

Body	C3604 BD
Bonnet	ZDC
Poppet	C3604 BD
Seat	NBR
Diaphragm	NBR
Safety valve seat	NBR

List of specifications

Series	Inlet Pressure Gauge MPa	Flowmeter				Inlet Connection	Outlet Connection
		Applicable gas	Flow L/min	Type of Flowmeter	Proof Pressure MPa		
FR-II	25	Ar	25	OUT	0.25	W22 (R)	Hose Nipple 8.5 mm
	25	Ar	25	OUT	0.2	W22 (R)	Hose Nipple 8.5 mm
	25	N ₂	25	OUT	0.2	W22 (R)	Hose Nipple 8.5 mm
	25	O ₂	25	OUT	0.2	W22 (R)	Hose Nipple 8.5 mm