

For Medical equipment

# NF Series

## Flowmeter of Oxygen for medical purposes

### Specifications

Applicable gas	Oxygen for medical purposes	Inlet Connection	Pin index style connector
Inlet Pressure	0.4MPa or less	Outlet Connection	Hose Nipple 9mm
Flow Range	0.2~10L/min	Accessories	Nil
Type of Flowmeter	IN	Approximate Weight	0.4kg



### Outline drawing

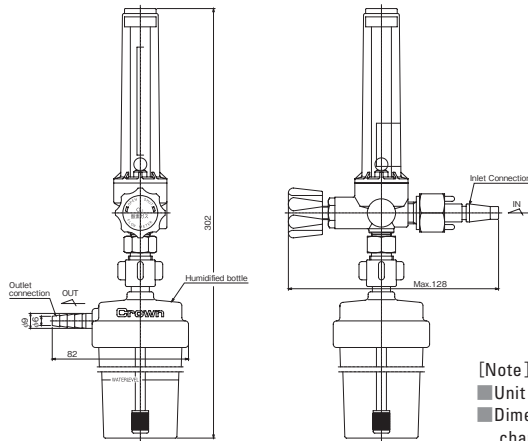

[Note]  
 ■ Unit : mm  
 ■ Dimensions are subject to change without notice.

### Materials of construction

Body	C3771BE
Bonnet	PC
Poppet	C3604BD
O Ring	NBR
Diaphragm	AS resin

# K Series

## Humidified bottle

### Specifications

Applicable gas	Oxygen for medical purposes	Outlet Connection	Hose Nipple 9mm
Maximum Outlet pressure	0.5MPa	Heatproof temperature	80°C
Maximum flowrate	15NL/min	Accessories	Nil
Inlet Connection	DISS connector for Oxygen (No.1240)	Approximate Weight	0.1kg

### Outline drawing

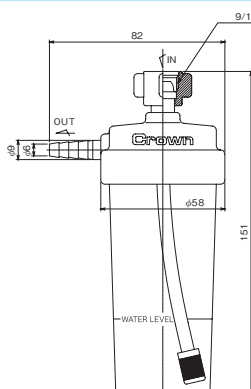

[Note]  
 ■ Unit : mm  
 ■ Dimensions are subject to change without notice.

### Materials of construction

Cover	Polyphenylsulfone
Bottle	PC
Tube	Polyolefin
Packing	NBR
Filter	PE

General industrial use

Flowmeter

Gas Mixer

Medical use